

METLOK 700[®]

DESIGN & INSTALLATION GUIDE

CONCEALED FIX ROOF SYSTEM



A Met-TECH[™] GUIDE

MARCH 2018



Metroll[®]

BETTER SERVICE • BETTER BUILDING SOLUTIONS

METLOK 700®



Sheet Width: 730mm Cover: 700mm Height: 40mm

Metlok 700® is a concealed fix roof system designed for long run roofing applications. It can also be used for walling. Metlok 700® is manufactured in a continuous roll form method from 0.42mm and 0.48mm BMT COLORBOND® steel, ZINCALUME® steel and galvanised steel. Metlok 700® is suitable for use in commercial and industrial applications for roof pitches as low as 1° (1 in 50).

Features & Benefits

- Concealed fix
- Ideal for long runs
- Low pitch
- Designed for thermal expansion and contraction
- Easy clip install

METLOK 700® - ROOFING

BMT mm	Steel Base Mpa	Mass CB* kg/m ²	Mass Zinc kg/m ²	Min. Pitch°	Max Spans mm	
					End	Internal
0.42	G550	4.72	4.66	1° (1 in 50)	1800	2200
0.48	G550	5.33	5.29	1° (1 in 50)	2200	2500

METLOK 700® - WALLING

0.42	G550	4.72	4.66	1800	2200
0.48	G550	5.33	5.29	2200	2500

*CB = Colorbond®

WIND UPLIFT RESISTANCE - LOAD SPAN TABLE DESIGN WIND PRESSURE (kPa)

Span (mm)	0.42 BMT				0.48 BMT			
	End		Internal		End		Internal	
	Service	Strength	Service	Strength	Service	Strength	Service	Strength
900	1.20	6.07	1.50	7.59	1.37	5.53	1.71	6.92
1200	1.18	4.10	1.47	5.13	1.28	4.60	1.60	5.75
1500	1.14	3.97	1.42	4.96	1.26	4.34	1.58	5.43
1800	1.09	3.82	1.36	4.78	1.25	4.09	1.57	5.18
2100	0.83	2.74	1.04	3.42	1.01	3.17	1.26	3.97
2200	0.74	2.37	0.93	2.96	0.92	2.05	1.15	2.56
2800					0.43	0.90	0.52	1.13

What is Met-TECH™?

Met-TECH™ is Metroll's Technical Resource Centre. It is the one stop shop for all of Metroll's product and technical information. Perfect for builders, contractors and specifiers to source all the information they may require. You can find other Met-TECH™ items on our website www.metroll.com.au/resources

**LOAD SPAN TABLE - DESIGN WIND PRESSURE (kPa)
METLOK 700® - ROOFING**

Span	0.42 BMT	0.48 BMT
	N2 or Region B TC3	
Single	2200	2500
End	1800	2200
Internal	2200	2500
Unstiffened Edge	150	150
Stiffened Edge	600	600

METLOK 700® - WALLING

Single	2200	2500
End	1800	2200
Internal	2200	2500
Unstiffened Edge	150	150
Stiffened Edge	600	600

Roof spans take account of 'normal maintenance' foot traffic and wind pressure. Wall spans take account of wind pressure only. Building height ≤ 7000mm. Cyclonic conditions are not covered by this table. Cpi = 0.3, - 0.2

Clips & Fasteners

Metlok 700® sheeting is fixed to supports by Metlok 700® Dekclips.

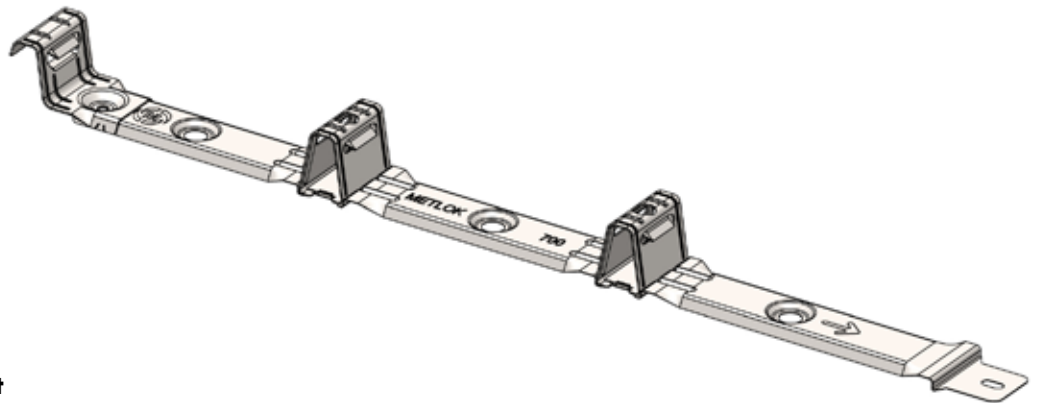

Metlok 700® Dekclip

Timber Supports - Hard or Soft

Roofing & Walling Type 17, 10 - 12 x 25mm

Steel Supports <2.5mm BMT

Roofing & Walling 10 - 16 x 16mm Hex Head

Steel Supports 2.5mm to 5mm BMT

Roofing & Walling 12 - 14 x 30mm Hex Head

NOTE: These fasteners do not make allowance for insulation blanket. **In all cases it is important the screw head diameter does not exceed 11.5mm.** Self drilling and tapping screws shall comply with AS3566.

Fastener Notes

10 - 16 Hex Head - Various Lengths

- Use Buildex Metal Tek Hex Head (no seal), or equivalent.
- Refer Buildex Data Sheet 31166; Part No. 6-311-3151-1C4.
- 16mm suitable for use with insulation up to 55mm.
- 25mm suitable for use with insulation up to 100mm.

12 - 14 x 30mm Hex Head

- Use Buildex Concealed Fix Screw (no seal), or equivalent.
- Refer Buildex Data Sheet 31231; Part No. 6-311-0782-2CS.
- 30mm suitable for use with insulation up to 100mm.

12 - 14 x 30mm Hex Head

- Use Buildex Hex Washer Type 17 (no seal), or equivalent.
- Refer Buildex Data Sheet 03103; Part No. 6-031-0053-8CS.
- 25mm suitable for use with insulation up to 100mm.

Drainage & Overflow

Max Roof Run (m) for Slopes & Rainfall Intensity						
Rainfall Intensity mm/hr.	Metlok 700® Roof Slope					
	1 in 50 1°	1 in 30 2°	1 in 20 3°	1 in 12 5°	1 in 7.5 7.5°	1 in 6 10°
100	245	306	365	442	355	610
150	166	210	245	306	357	416
200	122	158	179	225	265	310
250	101	125	142	180	212	250
300	82	103	120	155	170	210
400	76	92	107	136	160	186

- Rainwater run-off and drainage capacity may place some limitations on the total length of a sheet run and must be considered during the design and construction phase of a project.
- The total length of roof sheeting; which shall include end laps, expansion joints or steps and draining the roof in one direction, shall be considered as a single roof run.
- Thermal expansion must also be considered.
- Maximum production and transport lengths may limit availability.

Thermal Expansion

Change in temperature will cause all metals to expand and contract. There is minimal effect with steel roofing and walling, however care must be taken when long sheet runs and used and high temperature variations occur.

Length

Metroll supplies Metlok 700® cut to order as required; depending on load limit regulations set by local transport authorities. Lengths for manufacture need to be site measurements and not taken off plans. Length tolerance for Metlok 700® is $\pm 0 -15$ mm.

To prevent damage when lifting long lengths, ensure sheets are lifted with the use of multiple lift point spreader bars.

Cutting

Cut sheets with a method and in a location so that damage is avoided to sheets and other building products. Material should be cut on the ground and not above other materials. Remove all swarf and debris from the work and installation area. Sheets may be cut using a power saw with a steel cutting blade, a power nibbler or with tin snips. Avoid using abrasive discs as these can cause edge and coating damage.

Care, Handling & Storage

Care should be taken at all times when handling sheets to preserve the quality of the finish. Keep packs dry, stored clear of the ground and protected from rain and moisture. Any sheets which become wet should be separated, wiped and placed in the open air to dry.

Walking on Metlok 700®

When walking on Metlok 700® roof sheeting always wear flat rubber soled shoes and only walk over areas where purlins or batten supports are installed. Walk in either pan next to lapped edge ribs.

Clean Up

Prior to departing the work site remove all foreign debris, screws, rivets and especially any swarf created by drilling or cutting from the roof surface and/or inside gutters. Failure to do so may result in premature corrosion of the roof or gutters.

Material Compatibility

Never use lead flashings with Metlok 700® sheeting made from COLORBOND® and ZINCALUME® steels. Avoid drainage from copper roofs onto COLORBOND®, ZINCALUME® or galvanised steel roofing or rainwater products. Lead, copper, bare metal and some chemically treated timbers are not compatible with Metlok 700®.

Adverse Conditions

Localised environmental conditions can impact the corrosive nature of a site which may impact on material choice. Conditions that may impact on material choice include; direction of prevailing winds, rainfall intensity, duration of exposure, temperature, shelter and areas not washed by rainfall.

Contact your local Metroll branch if you intend to use Metlok 700® within 1km of industrial, chemical, marine or corrosive environments.

Material Specification & Scope

All roofing and walling should be specified on drawings as Metlok 700®, manufactured by Metroll Pty Ltd and installed in accordance with the manufacturers recommendations. Base sheet steel is G550 / AZ150 with specified finish.

Availability & Delivery

Metlok 700® is available from the national network of Metroll branches. Contact your local Metroll branch for lead times, colours and availability.

Ensuring suitable arrangements are made to assist the unloading of Metroll trucks will help supply material in good order. When lifting long lengths by crane please ensure the load is evenly spread. Where a crane cannot be made available it is the customers responsibility to provide sufficient labour to assist the driver in unloading.

Maintenance

Exterior surfaces not washed by rainfall should be washed on a regular basis.

Cyclonic Areas

The information contained in this publication is suitable for non-cyclonic areas only.

Alignment Check During Install

From time to time check that sheets continue to be parallel with the first sheet. This is done by taking two measurements across the width of one fixed sheet. Approximately half way through the job, perform a similar check from the finishing line.

Stop Ends & Lips - Pitch below 15°

Turn the pans at the top of the sheets up 90° using a turn-up tool to prevent wind driven water entry.

Turn the pans at the bottom of the sheets down 30° using a turn-down tool to prevent water running back along the underside of the sheet.

Roof Pitch, Flashings & End Laps

For roofs with continuous sheets and no end laps the minimum roof pitch is 1° (1 in 50). This minimum pitch must be adhered to and all points of the roof to prevent ponding. For roofs with end laps the minimum lap is 200mm for pitches between 5° and 15°, and 150mm above 15°. Allow a minimum of 50mm for projection into gutters.

Flashings must be of a compatible material and 150mm minimum cover.

For walls allow maximum end laps of 100mm. End laps in roofs of less than 5° should be sealed with a suitable sealant. The sealant should be applied in two runs; one at the low end of the lap to prevent moisture being drawn in by capillary action, the other should be at the high end of the lap to prevent condensation that may form under the top sheet from draining down the underside and entering the lap.

METLOK 700® INSTALLATION

Before Commencing Installation

Ensure cladding support is in the same plane. Ensure sheet overhang does not exceed recommendations. Check roof pitch is within minimum recommendations. For maximum hold, check first and last supports and clips are at least 75mm from the end of the sheet. Ensure set out is correct to avoid complicated post-install rectification.

Sheet Placement Prior To Install

Determine prevailing wind and weather direction for maximum weather tightness. Identify downward direction and start install from that end.

Turn sheets on the ground rather than on the roof, this is easier and safer. Before lifting ensure sheets are the correct way up and the overlapping side is facing the edge of the roof where installation will commence. Position sheet bundles over firm supports, not at mid span of roof members.

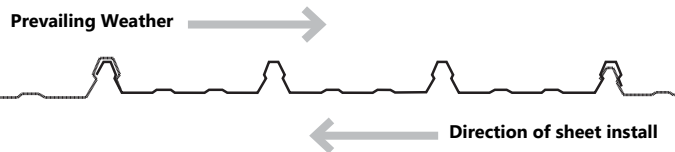

Installation Steps

1. Install safety wire and insulation as per manufacturers recommendations.
2. Position the first Metlok Dekclip by fixing to the support member nearest the roof edge.

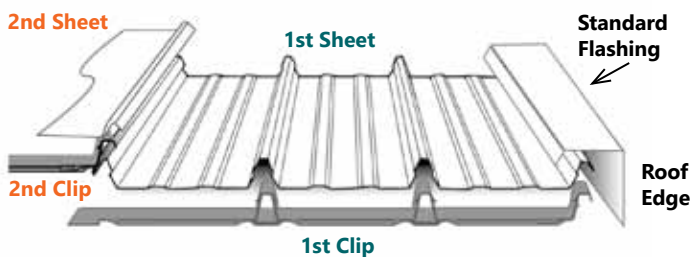

3. Fix the clip as indicated. Ensure the clip is 90° to the edge of the sheet and facing the direction required for laying.

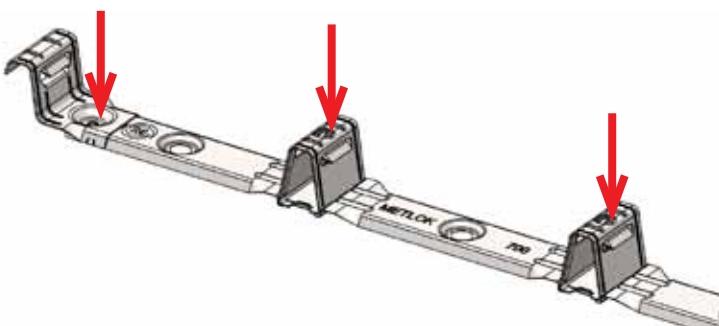

4. Using a string line align the clips using the first sheet as a straight edge. Fix a clip to each support member working towards the high end of the roof.

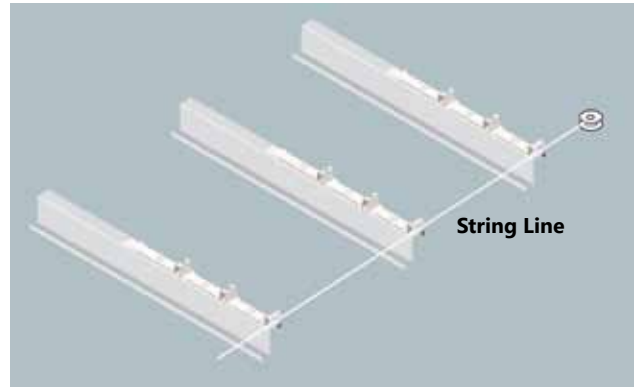

5. In accordance with the manufacturers recommendations, fix the Hex-head fasteners through the top of the clip into the support member.
6. Continue to work along the roof edge ensuring correct alignment at its ends relative to the gutter and ridge, (parapet or transverse wall).
7. Measure the distance from the gutter end of the sheet to the support.
8. The first sheet must be placed square to adjacent edges. Position the first sheet so it overhangs the desired amount (normally 50mm) into the gutter.

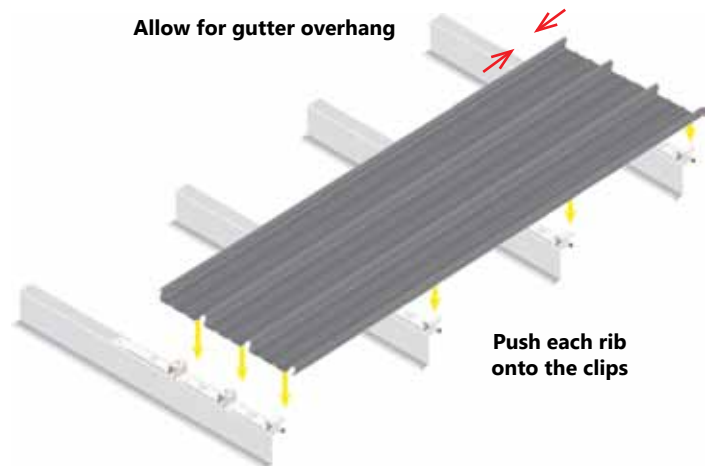

9. Secure the sheet by applying foot pressure on all ribs over each clip.

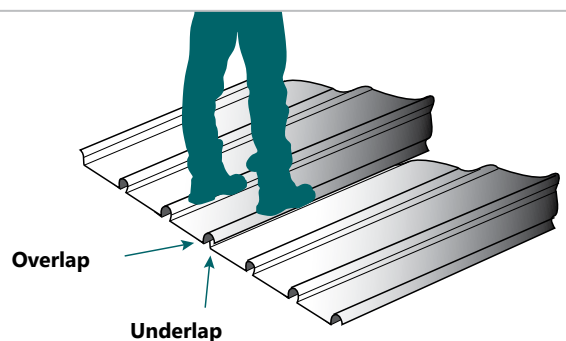

- Fix the next row of clips to the support members by engaging the front of the clip assembly onto the sheet underlap of the preceding sheet. Ensure the clip is 90° to the edge of the sheet. Second and all following clips are installed with the clip placed over the top of the underlap of the previous sheet.

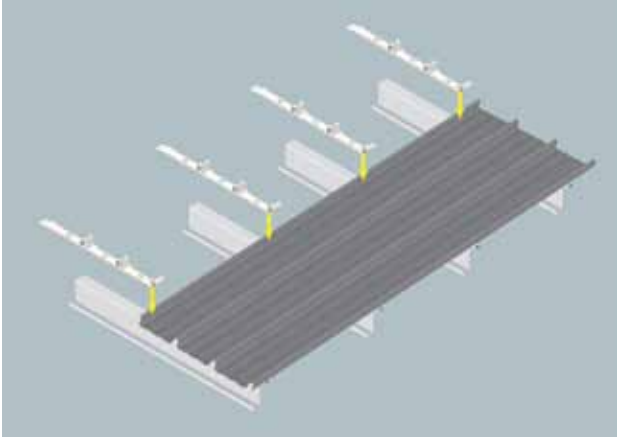

Close up of Metlok 700® Sheet & Clip Lap

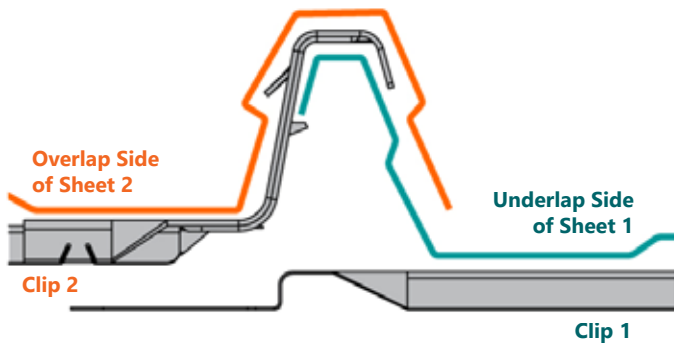

- Position the next sheet taking care to ensure it positively engages the full length of the edge of the preceding sheet.

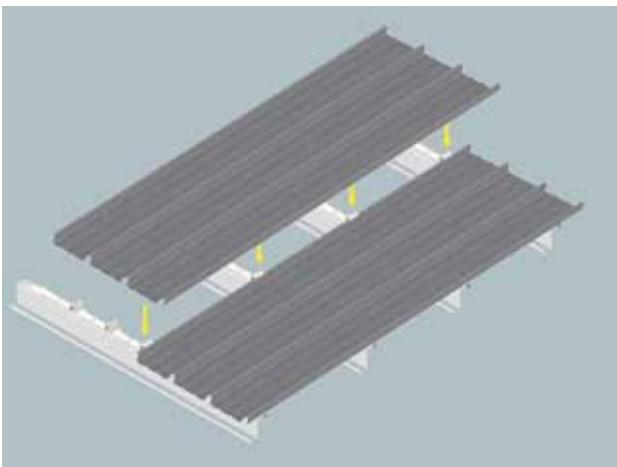

- Engage all clips and sheets as per Steps 9 - 11.
- If the final space is less than a full sheet width, the sheet can be cut and clips shortened as required.

Installation for Wall Applications

The procedure for walls is similar to roof installation. Sheets can be prevented from sliding downwards by pierce fixing through each sheet beneath the flashing or canopy along the top of the sheets.

Installation of Metlok 700® Translucent Sheets

Translucent sheeting experiences greater thermal expansion. As a consequence cladding should be fixed using oversized holes and sealing washers. Refer to fastener manufacturer for detail. When translucent sheeting is used in conjunction with concealed fixed cladding, ensure the fasteners do not penetrate the steel cladding. Do not exceed maximum span/support distances specified by the sheeting manufacturer.

Referenced Australian Standards

AS1170.2	SAA Loading Codes - Wind Loads
AS1397	Sheet & Strip Hot-Dipped Zinc Coated or Aluminium/Zinc Coated
AS1526	One Part Polysulphide-based Sealing Compounds for the Building Industry
AS1562.1	Design & Installation of Sheet & Wall Cladding, Part 1: Metal
AS2179	Specifications for Rainwater Goods, Accessories & Fasteners - Metal Shape or Sheet Rainwater Goods and Metal Accessories and Fasteners
AS2728	Prefinished/Prepainted Sheet Metal Products for Interior/Exterior Building Applications - Performance Requirements
AS3566	Self-drilling Screws for the Building & Construction Industries

Can we assist with any additional Steel Building Products?



QLD	
Cairns	07 4054 0888
Townsville	07 4779 8266
Mackay	07 4968 1255
Rockhampton	07 4920 0900
Bundaberg	07 4155 5999
Toowoomba	07 4634 6144
Sunshine Coast	07 5493 7872
Brisbane	07 3375 0100

NSW	
Lismore	02 6622 6677
Tamworth	02 6765 4799
Newcastle	02 4954 5799
Sydney	1300 766 346
Dubbo	02 6883 4800
Wagga Wagga	02 5924 4500

VIC	
Preston	03 9480 3744
Laverton	03 8369 8300
Geelong	03 5248 2006
Ballarat	03 5335 6416
Dandenong	03 8710 9300

TAS	
Launceston	03 6335 8555
SA	
Adelaide	08 8282 3300
WA	
Perth	08 9365 5444
Bunbury	08 9796 9796
Albany	08 9841 6966
Kalgoorlie	08 9022 3563
NT	
Darwin	08 8935 9555

26 Metroll Branches Nationwide

visit our new website
metroll.com.au



Metroll Pty Ltd. ABN 97 001 446 439. All reasonable care has been taken in the compilation of the information contained in this brochure. All recommendations on the use of Metroll products are made without guarantee as conditions of use are beyond the control of Metroll Pty Ltd. It is the customers responsibility to ensure that the product is fit for its intended purpose and that the actual conditions of use are suitable. Metroll Pty Ltd. pursues a policy of continuous development and reserves the right to amend specifications without prior notice. The Metroll M and Logo are registered trademarks of Metroll Pty Ltd.

COLORBOND®, ZINCALUME®, GALVASPAN®, AQUAPLATE® steels and Thermatech® are all registered trademarks of BlueScope Steel Limited.